

Three Phase Rectifier Bridge

PSD 68

$$I_{dAV} = 68 \text{ A}$$

$$V_{RRM} = 600-1600 \text{ V}$$

V_{RSM} V_{DSM} (V)	V_{RRM} V_{DRM} (V)	Type
700	600	PSD 68/06
900	800	PSD 68/08
1300	1200	PSD 68/12
1500	1400	PSD 68/14
1700	1600	PSD 68/16

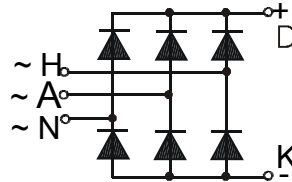

Features

- Package with DCB ceramic base plate
- Isolation voltage 3000 V~
- Planar glass passivated chips
- Low forward voltage drop
- Leads suitable for PC board soldering
- UL registered, E 148688
- RoHS conform

Applications

- Supplies for DC power equipment
- Input rectifier for PWM inverter
- Battery DC power supplies
- Field supply for DC motors

Advantages

- Easy to mount with two screws
- Space and weight savings
- Improved temperature and power cycling capability
- High power density
- Small and light weight

Package style and outline

Dimensions in mm (1mm = 0.0394")

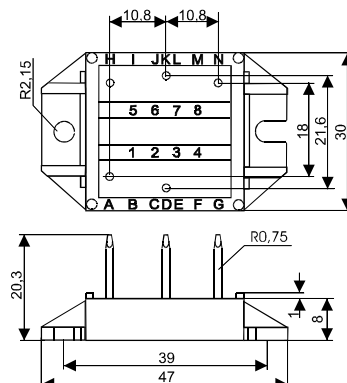

Symbol	Test Conditions	Maximum Ratings
I_{dAV}^*	$T_C = 100^\circ\text{C}$, (per module)	68 A
I_{FSM}	$T_{VJ} = 45^\circ\text{C}$ t = 10 ms (50 Hz), sine	300 A
	$V_R = 0$ t = 8.3 ms (60 Hz), sine	320 A
	$T_{VJ} = T_{VJM}$ t = 10 ms (50 Hz), sine	260 A
	$V_R = 0$ t = 8.3 ms (60 Hz), sine	280 A
$\int i^2 dt$	$T_{VJ} = 45^\circ\text{C}$ t = 10 ms (50 Hz), sine	450 A ² s
	$V_R = 0$ t = 8.3 ms (60 Hz), sine	425 A ² s
	$T_{VJ} = T_{VJM}$ t = 10 ms (50 Hz), sine	340 A ² s
	$V_R = 0$ t = 8.3 ms (60 Hz), sine	325 A ² s
T_{VJ}		-40... + 150 °C
T_{VJM}		150 °C
T_{stg}		-40... + 125 °C
V_{ISOL}	50/60 Hz, RMS t = 1 min	2500 V~
	$I_{ISOL} \leq 1 \text{ mA}$ t = 1 s	3000 V~
M_d	Mounting torque (M4)	1.5 - 1.8 Nm
		14 - 16 lb.in.
Weight	typ.	16 g

Symbol	Test Conditions	Characteristic Value
I_R	$V_R = V_{RRM}$, $T_{VJ} = T_{VJM}$	≤ 3 mA
	$V_R = V_{RRM}$, $T_{VJ} = 25^\circ\text{C}$	≤ 0.5 mA
V_F	$I_F = 55 \text{ A}$, $T_{VJ} = 25^\circ\text{C}$	≤ 1.46 V
V_{TO}	For power-loss calculations only	0.8 V
r_T		13 mΩ
R_{thJC}	per diode; DC	1.1 K/W
	per module	0.18 K/W
R_{thJK}	per diode; DC	1.6 K/W
	per module	0.27 K/W
d_s	Creeping distance on surface	11.2 mm
d_A	Creeping distance in air	9.7 mm
a	Max. allowable acceleration	50 m/s ²

Data according to IEC 60747 refer to a single diode unless otherwise stated
*- for resistive load at bridge output